

---

**ICMI Cyanide Code Gold Mining  
Applicability Determination for  
Closure Audit  
Summary Audit Report  
  
Goldcorp – Marlin Mine  
Guatemala**

**Submitted to:  
The International Cyanide Management Institute  
1400 I Street, NW – Suite 550  
Washington, DC 20005  
USA**



*December 15, 2017*



***Pamela Stella  
Environmental Mining Services LLC***

**Table of Contents**

**0.0 GENERAL..... 4**

**0.1 COMPANY INFORMATION ..... 4**

**0.2 LOCATION AND OWNERSHIP ..... 4**

**0.3 PROJECT DESCRIPTION BEFORE DECOMMISSIONING ..... 5**

**0.4 CYANIDE FACILITIES PRIOR TO DECOMMISSIONING ..... 7**

**0.5 DECOMMISSIONING PROGRAM OVERVIEW ..... 8**

    0.5.1 ICMC Decommissioning and Closure Audit Requirements ..... 9

    0.5.2 Marlin Closure Plan ..... 11

    0.5.3 Process Plant Closure Plan (Cleaning) ..... 17

**0.6 AUDITOR INFORMATION ..... 24**

**0.7 AUDIT FINDINGS ..... 25**

**DETAILED AUDIT REPORT.....26**

**1.0 PRODUCTION ..... 26**

**Encourage responsible cyanide manufacturing by purchasing from manufacturers who operate in a safe and environmentally protective manner. .... 26**

    Standard of Practice 1.1 ..... 26

**2.0 TRANSPORTATION ..... 27**

**Protect communities and the environment during cyanide transport. .... 27**

    Standard of Practice 2.1 ..... 27

    Standard of Practice 2.2 ..... 28

**3.0 HANDLING AND STORAGE..... 28**

**Protect workers and the environment during cyanide handling and storage..... 28**

    Standard of Practice 3.1 ..... 28

    Standard of Practice 3.2 ..... 30

**4.0 OPERATIONS ..... 31**

**Manage cyanide process solutions and waste streams to protect human health and the environment. .... 31**

    Standard of Practice 4.1 ..... 31

    Standard of Practice 4.2 ..... 33

    Standard of Practice 4.3 ..... 33

    Standard of Practice 4.4 ..... 36

    Standard of Practice 4.5 ..... 38

    Standard of Practice 4.6 ..... 40

    Standard of Practice 4.7 ..... 43

    Standard of Practice 4.8 ..... 43

    Standard of Practice 4.9 ..... 44

**5.0 DECOMMISSIONING ..... 45**

Goldcorp – Marlin Mine  
Name of Operation

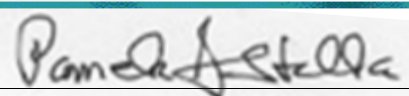
  
Signature of Lead Auditor

December 15, 2017  
Date

**Pamela Stella Environmental Mining Services LLC**

**Protect communities and the environment from cyanide through development and implementation of decommissioning plans for cyanide facilities. .... 45**

    Standard of Practice 5.1 ..... 45

    Standard of Practice 5.2 ..... 47

**6.0 WORKER SAFETY ..... 48**

**Protect workers’ health and safety from exposure to cyanide. .... 48**

    Standard of Practice 6.1 ..... 48

    Standard of Practice 6.2 ..... 49

    Standard of Practice 6.3 ..... 49

**7. 0 EMERGENCY RESPONSE ..... 50**

**Protect communities and the environment through the development of emergency response strategies and capabilities. .... 50**

    Standard of Practice 7.1 ..... 50

    Standard of Practice 7.2 ..... 50

    Standard of Practice 7.3 ..... 51

    Standard of Practice 7.4 ..... 51

    Standard of Practice 7.5 ..... 52

    Standard of Practice 7.6 ..... 52

**8.0 TRAINING ..... 53**

**Train workers and emergency response personnel to manage cyanide in a safe and environmentally protective manner ..... 53**

    Standard of Practice 8.1 ..... 53

    Standard of Practice 8.2 ..... 53

    Standard of Practice 8.3 ..... 54

**9.0 DIALOGUE ..... 54**

**Engage in public consultation and disclosure. .... 54**

    Standard of Practice 9.1 ..... 54

    Standard of Practice 9.2 ..... 56

    Standard of Practice 9.3 ..... 57

**REFERENCES ..... 58**

Goldcorp – Marlin Mine  
Name of Operation

  
Signature of Lead Auditor

December 15, 2017  
Date

**Pamela Stella Environmental Mining Services LLC**

**0.0 GENERAL****0.1 COMPANY INFORMATION**

**Name of Mine:** Marlin Mine  
**Name of Mine Owner:** Goldcorp Inc.  
**Name of Mine Operator:** Montana Exploradora de Guatemala S.A.  
**Name of Responsible Manager:** Christian Roldan  
**Address:** Europlaza World Business Center 5a Avenida 5-55 Zona 14  
Torre 1, Nivel 6, Oficina 601  
**State/Province:** Department of San Marcos  
**Country:** Guatemala  
**Telephone:** (502) 232 92600  
**Fax:** (502) 232 92610  
**E-Mail:** [Christian.Roldan@goldcorp.com](mailto:Christian.Roldan@goldcorp.com)

**0.2 LOCATION AND OWNERSHIP**

Marlin is operated by Montana Exploradora de Guatemala, S.A. (Montana), a subsidiary of Goldcorp Inc. Marlin is located in the western highlands of Guatemala at an elevation of approximately 2,100 meters above sea level, about 276 kilometers (km) west-northwest of Guatemala City (Figure 1). Marlin was a gold and silver mine and processing facility located in the municipalities of San Miguel and Sipacapa, in the Department of San Marcos. The mining concession is 20 square kilometers. Rainfall at the Marlin site is estimated to average approximately 1,200 millimeters (mm) per year and occurs primarily during the wet season when about 90 percent of the annual precipitation occurs. The average annual pan evaporation is 1,450 mm.

---

Goldcorp – Marlin Mine  
Name of Operation

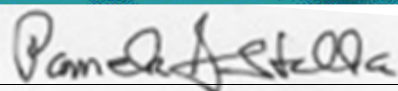
  
Signature of Lead Auditor

December 15, 2017  
Date

**Pamela Stella Environmental Mining Services LLC**

**LOCALIZACION**



Figure 1 Project Location

**0.3 PROJECT DESCRIPTION BEFORE DECOMMISSIONING**

Marlin commenced operation in late 2005 and ceased operation on May 30, 2017. During operation, Marlin employed approximately 1,500 direct workers and 356 contractors. Currently there are about 127 direct workers.

Mining previously occurred using both underground and open pit methods. However, open pit mining ceased in 2011 and only underground mining continued until May 2017. Ore was hauled approximately 2 km from the mine to the crushing and grinding facility. The mill throughput average was approximately 5,000 tonnes per day (tpd).

Goldcorp – Marlin Mine  
Name of Operation

*Pamela Stella*  
Signature of Lead Auditor

December 15, 2017  
Date

**Pamela Stella Environmental Mining Services LLC**

Marlin received cyanide produced by the Chemours Company in Intermediate Bulk Container (IBC) boxes. IBCs were stored in a warehouse and periodically moved, using first in/first out principles, to a smaller storage area adjacent to the mixing area at the plant. Box components (i.e., plywood, cardboard, and plastic bags) were temporarily stored in a secure area at the mixing area for periodic transport to the onsite incinerator where they were burned.

Marlin's cyanide circuit consisted of a gravity concentrator and intensive cyanidation reactor (inactive since 2007), grinding thickener, pregnant solution storage tank, cyanide mixing tank, cyanide storage tank, process water storage tank, seven leach tanks, six counter current decantation (CCD) tanks, cyanide recovery thickener and interconnection pipes. The ground ore was processed in tanks by an agitated leach in a cyanide solution. The resulting product was passed through a CCD system and the Merrill-Crowe circuit. Gold and silver were recovered in the onsite refinery. The dore' was shipped off site for further refining and sale.

The process circuits are shown in the process flow diagram in Figure 2. The tailings from the CCD were treated by an Inco/SO<sub>2</sub> system to neutralize the residual weak acid dissociable (WAD) cyanide concentrations to approximately 0.5 mg/L prior to passing to a filter plant or the Tailings Storage Facility (TSF). Tailings directed to the filter plant were filtered to approximately 85 percent solids and deposited as backfill into the open pit. Upon closure of the open pit filtered tailings were no longer sent to the pit. Water from the filter plant was returned to the leach plant for re-use in the process circuit. Tailings were directed to the TSF and were strategically deposited around the perimeter to move the decant pool in the direction of the spillway in preparation for closure. Marlin operated a water treatment plant that treated the water from the tailings reclaim and then returned the water back to the TSF for reuse during the dry season or for discharge through the spillway during the wet season, if the Free cyanide concentrations were below 0.022 mg/l. Marlin is permitted to discharge water and is doing so during the wet season to reduce the size of the decant pool in preparation for final closure of the TSF.

---

Goldcorp – Marlin Mine  
Name of Operation

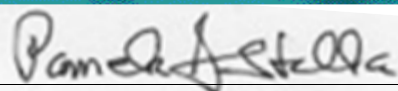
  
Signature of Lead Auditor

December 15, 2017  
Date

**Pamela Stella Environmental Mining Services LLC**

The TSF has a phased earth and rockfill embankment. The embankment has an inclined, low-permeability core, and a grout curtain to control seepage through the embankment foundation, internal drainage and a dam seepage collection system. Construction of a concrete closure spillway was completed in 2014. Diversion channels were built on either side of the TSF in 2015 to reduce the amount of water reporting to the facility.

Figure 2: Process Flow Diagram During Operations (supplied by Marlin)

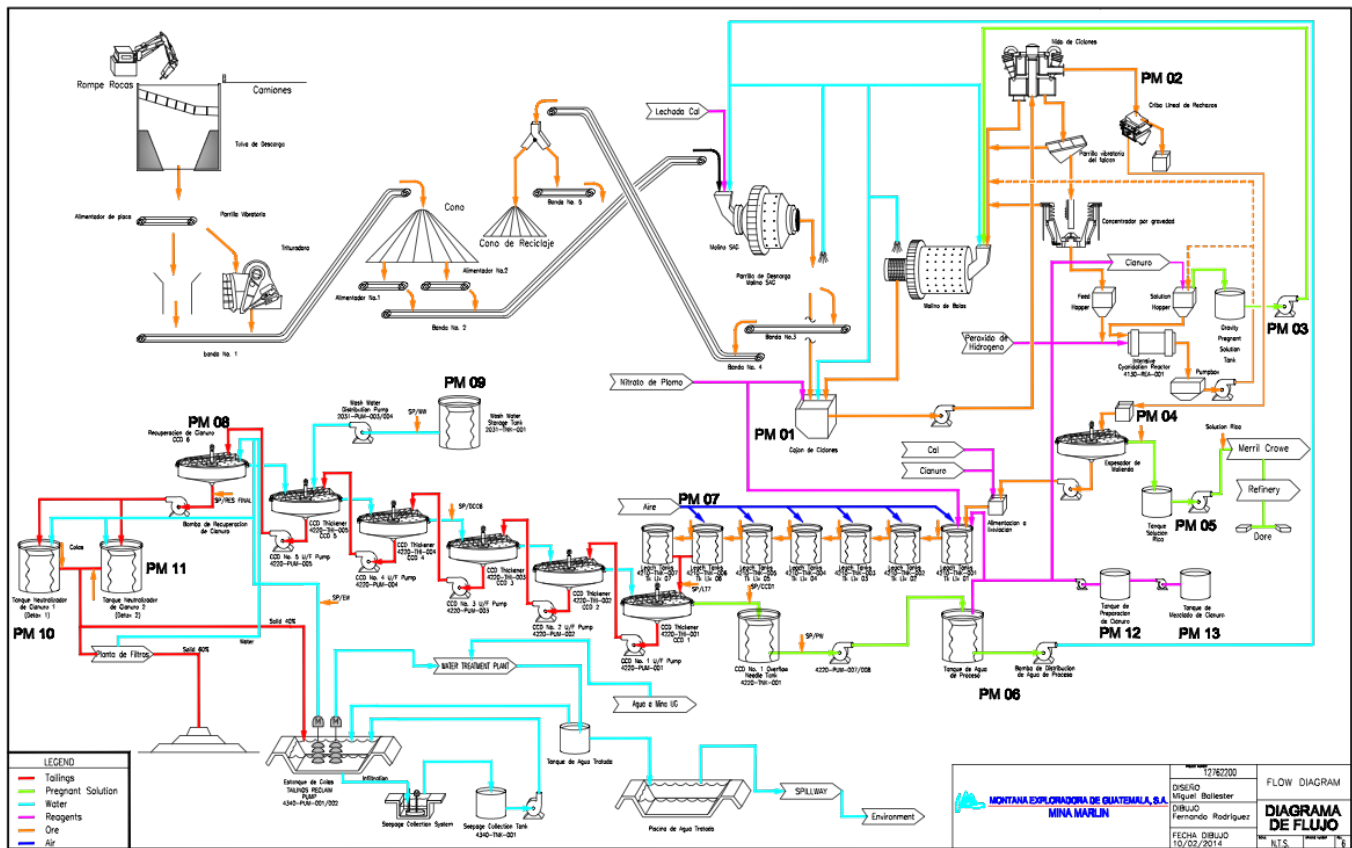

**0.4 CYANIDE FACILITIES PRIOR TO DECOMMISSIONING**

Goldcorp – Marlin Mine  
Name of Operation

*Pamela Stella*  
Signature of Lead Auditor

December 15, 2017  
Date

**Pamela Stella Environmental Mining Services LLC**

Goldcorp completed decommissioning activities associated with the Marlin cyanide facilities on September 22, 2017 (see **Section 0.5** below). Therefore, the Marlin Mine currently has no active cyanide facilities.

The cyanide facilities that were active prior to decommissioning activities are as follows:

- . Cyanide Storage Warehouse
- . Cyanide Preparation Area
- . Milling Circuit
- . Gravity concentrator and intensive cyanidation reactor (inactive since 2007)
- . Leach Circuit
- . Counter current decantation (CCD) Circuit
- . Merrill-Crowe Plant
- . Cyanide Destruction Circuit
- . Tailings Filtration Plant
- . Tailings Storage Facility
- . Stormwater Diversions
- . Seepage Collection Pond and
- . Associated concrete and lined secondary containment structures, sumps, process solution transfer pipes, valves and pumps.

## **0.5 DECOMMISSIONING PROGRAM OVERVIEW**

This section of the audit report describes the Marlin Decommissioning Program framework and the activities performed to decommission the cyanide facilities. Section 1.0 through Section 9.0 of this report addresses each specific ICMC Principle and the corresponding Standards of Practice. The findings presented in Sections 1.0 through 9.0 are based on evidence summarized in this section.

---

Goldcorp – Marlin Mine  
Name of Operation

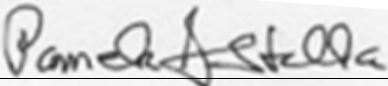
  
Signature of Lead Auditor  
**Pamela Stella Environmental Mining Services LLC**

December 15, 2017  
Date



**0.5.1 ICMC Decommissioning and Closure Audit Requirements**

The Code defines decommissioning as:

*“The activities conducted to treat, neutralize or otherwise manage cyanide and cyanide containing process solutions remaining in storage and production facilities in preparation for closure so that they do not present a risk to people, wildlife or the environment due to their cyanide content. Decommissioning includes decontamination of equipment, removal of residual cyanide reagents, rinsing of heap leach pads and installation of measures necessary for control or management of surface or ground water, such as pumping and treatment systems that would operate during the facility's closure period. Decommissioning does not include activities such as physical stabilization of tailings storage facilities (TSF) or heaps, revegetation of disturbed land or long-term management of seepage from leaching facilities or TSFs or environmental monitoring.”*

The findings presented in this audit report provide verification that Goldcorp has successfully decommissioned the Marlin cyanide facilities in accordance with this definition. However, the Code does not require certified mines to undergo decommissioning or closure audits.

Participation in the Code is voluntary; therefore, mines can withdraw from the program at any time and for any reason. A mine is no longer subject to Code certification after decommissioning of its cyanide facilities. A certified mine has three (3) options as gold production ends, which include:

- 1) **Withdrawal from the Cyanide Code:** A certified mine can elect to withdraw from the Code program rather than getting its next triennial certification audit by submitting an updated signatory application form to the International Cyanide Management Institute (“ICMI”). Although no reason for the withdrawal is required, the signatory can indicate that the

Goldcorp – Marlin Mine  
Name of Operation

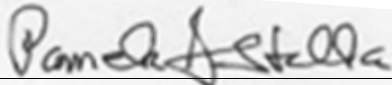
  
Signature of Lead Auditor

December 15, 2017  
Date

**Pamela Stella Environmental Mining Services LLC**

operation is nearing the end of production, is in its decommissioning phase or has fully decommissioned all cyanide facilities and therefore is no longer subject to the Code.

- 2) Certification prior to or during decommissioning: An operation can be audited prior to or during its decommissioning and it can be certified in compliance with the Code as long as cyanide facilities remain on site. The audit would determine if remaining cyanide facilities and their management continue to be compliant with the Code during decommissioning, and document those aspects of the mine that are no longer subject to the program. As with all certifications, the Summary Audit Report and Auditor Credentials Form will be posted on the ICMC website demonstrating to stakeholders that the mine maintained compliance with the Code as it was decommissioned.
- 3) Audit after decommissioning: A mine that has been decommissioned can be audited to determine if cyanide facilities remain on site or if the Code is no longer applicable. If the auditor determines that cyanide facilities no longer exist, the audit report can document the evidence supporting this finding for each Principle and Standard of Practice and demonstrate that the risks related to cyanide have been minimized to the point that the Code no longer applies. The mine’s decommissioning cannot be certified because it is no longer within the scope of the ICMC program. However, at the signatory’s request, ICMI can post the Summary Audit Report and Auditor Credentials Form along with an announcement that the operation has been withdrawn from certification.

This *Applicability Determination for Closure Audit* was conducted following full decommissioning of the Marlin cyanide facilities (option No. 3 above) in order to verify that all ICMC Principles and corresponding Standards of Practice provided in the *ICMI Gold Mining Operations Verification Protocol* no longer apply to the Marlin Mine. The objective of the audit was to determine if cyanide facilities remain on site or if the Marlin Mine is no longer subject to the Code. Currently the only mine to apply the *Applicability Determination for Closure Audit* was Goldcorp’s El Sauzal Mine in Mexico in 2015.

Goldcorp – Marlin Mine  
Name of Operation

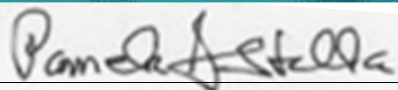
  
Signature of Lead Auditor

December 15, 2017  
Date

**Pamela Stella Environmental Mining Services LLC**

ICMC recertification audits typically focus on verifying an operation's continued compliance with the Code over the three-year period between audits. However, because the Marlin Mine was recently recertified in May 2016 as being in full compliance with the Code, this final audit serves exclusively to verify that the Marlin Mine is no longer subject to the Code rather than to verify that the operation has or is meeting all of the Code Principles and Standards of Practice. Consequently, this audit does not reconsider determinations from the 2016-recertification audit. The auditor placed particular emphasis on evaluating measures implemented by Goldcorp to decommission the Marlin cyanide facilities and remove residual cyanide reagents pursuant to Code requirements, which included evaluating the need to install measures necessary to control or manage surface water such as surface water diversions that will operate during the mine's closure period. The auditor also evaluated whether cyanide is still being transported to the Marlin Mine, stored on site, or used on site for the recovery of gold.

Because the Code is only concerned with decommissioning of cyanide facilities, the auditor did not evaluate the need for or performance of any ongoing closure or post-closure facility inspections, maintenance and environmental monitoring programs; or water management activities; only that necessary water management systems are in place, if warranted.

### **0.5.2 Marlin Closure Plan**

The *Marlin Closure Plan* (dated November 2014) presents the general closure activities proposed for the entire operation's site. The Closure Plan (the Plan) describes the requirements and objectives of closure, applicable guidelines and requirements, post-closure property state and soil use, closure objectives, location and availability of material for closure and revegetation and closure design criteria. The Plan details the measures to fully close the mine installations, the waste rock facility, the mill and process facilities, tailings storage facility and site infrastructure. The mine facilities included in the Plan include the underground mine, mine pits, mining equipment and monitoring. Site infrastructure covered by the Plan includes electrical equipment,

---

Goldcorp – Marlin Mine  
Name of Operation

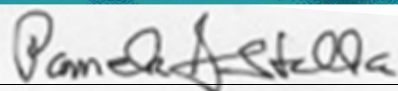
  
Signature of Lead Auditor

December 15, 2017  
Date

**Pamela Stella Environmental Mining Services LLC**

water supply, the maintenance shop, administration offices, mine camp, solid waste, roads, miscellaneous buildings and ancillary facilities, and the crushing and screening circuit.

Relevant to the ICMC, Sections 5.0 and 6.0 of the Plan present the general closure activities for the Milling and Process Area and the TSF respectively. More specifically, the cyanide-related facilities covered in Section 5.0 include the TSF, seepage collection pond, cyanide storage, assay lab, refinery, and process and process water treatment plant circuits including equipment, tanks, mills, filtration and clarifier components, pumps, piping, sumps, process buildings and interior fixtures, and concrete foundations.

The materials that are associated with the processing, treatment of process water or tailings removal will be buried in the TSF or the Waste Rock Facility. Materials that are not suitable (due to their waste classification) for final disposal in the TSF or Waste Rock Facility (such as fuels or special oils) will be transported to an appropriate off-site facility.

The dismantling of all facilities related to cyanide was in accordance with the standard of practice listed in Principle 5 of the Cyanide Code (ICMI, 2016). This included the tasks listed below.

1. All cyanide was consumed in the final stages of operations so it was not necessary to return any cyanide to the vendor.
2. Decontamination of all processing equipment and structural components associated with the cyanide process. At the end of rinsing, all rinse water analytical values for cyanide weak acid dissociable (WAD) cyanide were below 0.5mg / L.
3. Reduction of the concentrations of cyanide in the waste materials to levels protective to human health, wildlife and the environment. WAD cyanide concentrations in rinse water was less than 0.5 mg/L for discharge into the TSF and the treated water discharged into streams was less than 0.022 mg / L.

Goldcorp – Marlin Mine  
Name of Operation

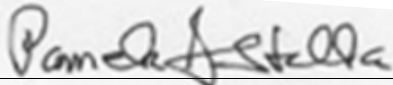
  
Signature of Lead Auditor

December 15, 2017  
Date

**Pamela Stella Environmental Mining Services LLC**

Auditor reviewed water quality data to verify that rinse solutions or direct treatment were stabilized in accordance with the applicable standards listed above and discharged into the TSF.

Following is a brief summary of the closure activities for the various process components and the TSF, as presented in the 2014 Marlin Closure Plan.

### **Tailing Storage Facility (TSF)**

The TSF is located immediately north of the process plant. The facility design and construction includes the following elements:

- The TSF has a phased earth and rockfill embankment constructed over a bedrock foundation.
- The embankment has an inclined, low- permeability core, a grout curtain to control seepage through the embankment foundation, internal drainage and a dam seepage collection system.
- The TSF was constructed with a main dam across the drainage and a saddle berm along the eastern flank.
- Expansion phases were completed using downstream construction.
- Tailings were deposited by subaerial deposition.

The main dam is constructed with a compacted low permeability core keyed into bedrock with a trench. The low permeability core is buttressed on the upstream slope by a toe cofferdam and rock shell fill. The low permeability core is buttressed on the downstream slope by a vertical rock filter drain, rock drain and rock shell fills. The vertical drain is connected at the base to a main drain that takes dam seepage out to a collection pond. To limit seepage beneath the embankment and through the abutments, the grout curtain was installed to intercept zones of higher permeability foundation materials. The tailings design included detailed hydrogeologic characterization before and after the grouting program to define the permeability of the foundation and grout curtain.

---

Goldcorp – Marlin Mine  
Name of Operation

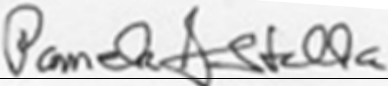
  
Signature of Lead Auditor  
**Pamela Stella Environmental Mining Services LLC**

December 15, 2017  
Date

The TSF embankment includes internal drainage to provide an engineered path to collect, route, and manage water infiltrating into, around, and through the dam. The drain system consists of a chimney drain installed along the downstream side of the dam's low permeability core and a main drain constructed along the valley bottom from the base of the chimney drain to a discharge point at the toe of the dam. A seepage collection pond, located at the toe of the TSF embankment, intercepted and stored seepage from this main drain. Prior to decommissioning, seepage collected in the pond was pumped back to the TSF. However, water quality in the pond is currently below 0.01 mg/L of WAD cyanide and is therefore able to be discharged directly into a creek (quebrada).

Marlin had stored meteoric water in the TSF to maintain water availability for the processing plant during the dry season. A concrete closure spillway was constructed in 2014 to discharge excess rainwater that had accumulated in the TSF. Diversion channels were built on either side of the TSF in 2015 to reduce the amount of water reporting to the facility.

In May 2011 the dam was completed and currently has a final peak elevation of operation at the 1962.5 m elevation. It has a height of 88 m and its slope was completely re-vegetated with grass seed that provides food for cattle.

The Closure Plan describes decommissioning of the TSF in accordance with applicable permit conditions and corporate guidelines based on Goldcorp's experience gained during operation and successful decommissioning and closure of similar facilities. The closure of the TSF includes:

- Removal of excess water from the tailings surface via the water treatment plant to comply with applicable discharge standards
- The placement of an inclined cover over the tailings surface and
- Revegetation of the cover.

---

Goldcorp – Marlin Mine  
Name of Operation

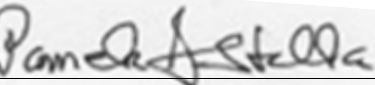
  
Signature of Lead Auditor

December 15, 2017  
Date

**Pamela Stella Environmental Mining Services LLC**

The stormwater management controls around the TSF perimeter and the inclined closure cover will promote the removal of meteoric water in and around the TSF. Upon placement of the cover, growth media and revegetation will limit infiltration of meteoric water on the TSF surface.

There are several control measures that Marlin implemented to ensure the short- and long-term slope stability of the TSF. These measures include:

- Design and construction management
- Slope stability analysis
- Low permeability underlying bedrock foundation conditions
- Seepage control
- Tailings deposition management during operations
- Use of downstream construction practices during expansion phases and
- Stormwater management controls.

### **Cyanide Storage Facility**

Solid cyanide was stored in IBC boxes inside a cyanide warehouse. Cyanide was mixed in a cyanide mix tank and then pumped to a cyanide distribution tank. During closure of the processing plant, all cyanide was consumed and cyanide mix and storage tanks were emptied and rinsed, with resulting rinse solution sent to the leach tanks. The tanks will be sold, recycled, cut up and/or crushed and buried in the TSF.

### **Assay Lab and Refinery**

Refractory linings of fire assay furnaces were removed and shipped to an approved off-site facility for the handling of lead contaminated wastes. All chemicals from the refinery were consumed, removed from the site to an approved disposal location or sold. Equipment related to the production of gold/silver doré were cleaned of residual dust and contaminants, and

---

Goldcorp – Marlin Mine  
Name of Operation

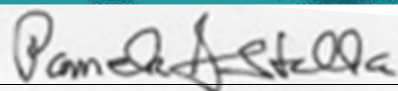
  
Signature of Lead Auditor

December 15, 2017  
Date

**Pamela Stella Environmental Mining Services LLC**

dismantled, sold or disposed of in an approved on- or off-site facility. Ventilation equipment was removed and dust found in the system was collected and removed from the site to an approved disposal location and/or sold.

### **Process Tanks, Mills, Filters and Steel Sumps**

These facilities include tanks utilized in the process circuits and the Cyanide Destruction Circuit, the milling and Tailings Filtration Plant equipment, and the sumps in the process areas. The equipment and tanks were emptied and rinsed of all remaining process chemicals and sludge. The rinse water and sludge were sent to the tailings thickener, the cyanide destruction circuit and ultimately deposited in the TSF. The tanks were rinsed to remove related process scale, piping and pumps. The tanks will be dismantled sold, recycled, or cut up and/or crushed and buried in the TSF.

### **Process Piping**

The process piping contained within the facilities were rinsed or stabilized with appropriate chemicals. The resulting solution was removed and sent to the tailings thickener and ultimately deposited in the TSF. Piping was cut into sections and sold as scrap.

### **Process Pumps and Equipment**

The process pumps, contained within the processing facilities, were rinsed or stabilized with appropriate chemicals. The resulting solution was sent to the tailings thickener, detox and ultimately deposited in the TSF. The pumps were sold.

### **Chemicals**

All chemicals from these facilities were consumed, removed from the site to an approved disposal location or sold. Equipment exposed to hazardous chemicals was rinsed prior to removal. Rinse water was sent to the Tailings Thickener and ultimately deposited in the TSF. The equipment will be dismantled and sold, recycled for scrap or buried in the TSF.

---

Goldcorp – Marlin Mine  
Name of Operation

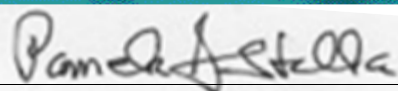
  
Signature of Lead Auditor

December 15, 2017  
Date

**Pamela Stella Environmental Mining Services LLC**



**Building and Interior Fixtures**

The process buildings are typically steel frame structures covered with metal roofing on concrete foundations. Upon removal of process equipment as outlined above, the buildings and interior fixtures, decking, steel stairways, steel doorways, aluminum materials, and electrical equipment, will be triple rinsed or stabilized with appropriate chemicals depending on their exposure to cyanide or other hazardous chemicals. Once determined to be chemically stable, the buildings and interior fixtures will be dismantled, with the steel structure sold, recycled or buried in an approved on-site facility (TSF or Waste Rock Facility).

**Concrete Foundations**

Concrete foundations that have been exposed to cyanide or other hazardous chemicals will be triple rinsed. The rinse solution will be placed in the TSF. The foundation of the cyanide warehouse was not rinsed because there had never been any cyanide spills in the warehouse. Upon final cleaning of the foundations, the concrete will be reclaimed either by directly burying the concrete or by breaking up the concrete before burying to avoid ponding of water. In both cases, the area will be covered with growth media and seeded.

**0.5.3 Process Plant Closure Plan (Cleaning)**

During 2015, Goldcorp began reclamation and closure activities as part of the Marlin Mine closure process planned for completion in the second quarter of 2017. Reclamation activities conducted in 2015 focused on backfilling the pit, recontouring the waste rock storage areas, revegetating disturbed areas, and final placement of tailings in the TSF on June 1, 2017. Goldcorp completed decommissioning and cleaning of the Marlin cyanide facilities from May 31 to September 22, 2017 and plans to complete full closure of the processing facilities by the last quarter of 2017.

---

Goldcorp – Marlin Mine  
Name of Operation

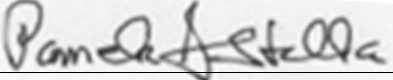
  
Signature of Lead Auditor  
**Pamela Stella Environmental Mining Services LLC**

December 15, 2017  
Date

Goldcorp's Sustainability Excellence Management System (SEMS) Framework and Standards (June 2017) include Standards 9 and 10, International Cyanide Management Code and Reclamation and Closure Planning. The SEMS has been formally adopted as the Corporate standard and implementation guideline for environmental stewardship. These Standards allow Goldcorp mining operations to comply with all applicable local laws and regulations, international guidelines and the ICMC, and results in returning mine sites to long-term safe and stable conditions.

Standard 10 also requires that stakeholders must be informed when there is a significant material change at the site. The Standard includes requirements for:

- Terms of reference for reclamation and closure activities will be explicitly documented in the life-of-mine closure plan.
- Applicable regulatory standards, closure performance objectives, permitting and approval requirements, and procedures for release of financial assurance upon completion of the work
- Clear definition of the pre and post-mining land use, evaluation of alternative sustainable uses, and a discussion of land ownership/transfer mechanisms
- A clear definition of key technical and social assumptions, with a list of data requirements pre and post closure
- A schedule of closure activities to address impact assumptions and gaps
- A closure-focused engagement plan
- Community development initiatives during the closure phase, including how operations phase initiatives will be concluded or handed off
- Consideration of local and regional partnerships and agreements.

As outlined in the Standards, Goldcorp operations must prepare a final decommissioning plan for submittal to regulatory agencies as appropriate. Although the Guatemalan government does not

---

Goldcorp – Marlin Mine  
Name of Operation

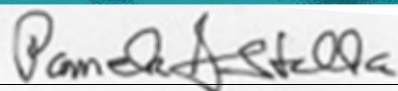
  
Signature of Lead Auditor

December 15, 2017  
Date

**Pamela Stella Environmental Mining Services LLC**

require a closure plan, Marlin developed a detailed report titled the *Process Plant Closure Plan (Cleaning) (the Plan)* (dated September 2016). This Plan describes the actual decommissioning activities that Goldcorp planned to conduct to treat, neutralize or otherwise manage cyanide and cyanide containing process solutions remaining in storage and process facilities in preparation for closure. This Plan is based on the cleaning and dismantling of all areas: Grinding, Crushing, Preparation and Dosing of Cyanide, Thickeners, Leaching, Cyanide Destruction Tank, Process Water Tanks, Grinding Thickener, CCDs and Tailings Thickener, Leaching Tanks, Washing Water Tank, Detox Tanks 1 and 2, Reagent Tanks, Merrill Crowe, Refinery Area, Retorts, Condenser and its accessories, Filter Plant and Water Treatment Plant.

In February 2017, Goldcorp submitted the Plan to the Directorate of Environmental Management Ministry of Environment and Natural Resources (MENR). Marlin also conducted a meeting with the MENR to discuss the Plan and address any concerns or questions of the MENR. The MENR requested some changes to the Plan. Marlin resubmitted the Plan on June 28, 2017 addressing MENR changes. On November 14, 2017 the MENR requested additional information from Marlin. Marlin will address this information request by December 15, 2017.

The last cyanide mix occurred on May 30, 2017. Milling stopped on May 31, 2017. Rinsing of the process plant facilities started on May 31, 2017 and finished on September 22, 2017. The only decommissioning activities remaining at the time of this audit were dismantling and demolition and final closure of the TSF. Goldcorp followed its written procedure, "*Cleaning of Process Plant Tanks (July 2015)*" and the Process Plant Closure Plan that includes the detailed steps implemented. The following is a summary of the decommissioning activities completed for the Marlin cyanide facilities as presented in the *Process Plant Closure Plan*.

**Grinding Circuit**

On May 31, 2017, Goldcorp stopped the SAG and Ball Mills and started rinsing the grinding circuit in a closed loop. The first 8 rinse cycles were with fresh water and lime. The last rinse

---

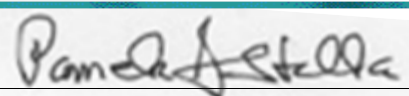
Goldcorp – Marlin Mine		December 15, 2017
Name of Operation	Signature of Lead Auditor	Date
<b>Pamela Stella Environmental Mining Services LLC</b>		
Page 19 of 58		

cycle was fresh waste and sodium hydroxide. The rinse water was sent to the Grinding Thickener. The Falcon/Gecko and cyclones were rinsed on June 6, 2017.

In order to determine the effectiveness of rinsing, samples were taken at the cyclone feed pumpbox, the cyclone nest and the grinding pregnant solution tank, for WAD, Free and Total cyanide concentrations. The auditor reviewed the analytical data from the external laboratory and verified that the WAD cyanide concentrations were below 0.5 mg/l.

Based on the analytical data, the site inspection and interviews with the Production Plant Manager, Marlin has decommissioned the grinding circuit.

### **Cyanide Preparation Area**

In June 2017, Goldcorp emptied the Sodium Cyanide Mixing Tank and the Sodium Cyanide Distribution Tank and began neutralizing, decontaminating and washing the two tanks using caustic soda and sodium hypochlorite.

During emptying, the tanks were drained to the concrete containment sump and the solution was pumped to the Grinding Thickener. After rinsing repeatedly for nine cycles, using the tank agitators to thoroughly mix the neutralizing solution, the residual rinse solution was pumped to the leach tank 1 and combined with the residual rinse solution from the other process circuits.

In order to determine the effectiveness of rinsing, samples were taken in the cyanide preparation and distribution tanks for WAD, Free and Total cyanide concentrations. The auditor reviewed the analytical data from the external laboratory and verified that the WAD cyanide concentrations were below 0.5 mg/l.

On June 13, 2017, Goldcorp completed rinsing both tanks and the sumps and concrete containment areas, thus ending decommissioning activities for the Cyanide Preparation Area.

---

Goldcorp – Marlin Mine  
Name of Operation

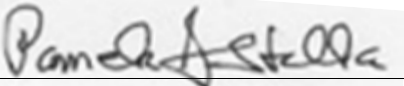
  
Signature of Lead Auditor  
**Pamela Stella Environmental Mining Services LLC**

December 15, 2017  
Date

Based on the analytical data, the site inspection and interviews with the Production Plant Manager, Marlin has decommissioned the Cyanide Preparation Area.

### **Process Circuits**

Goldcorp started the process plant rinse operations and releasing the residual rinse water to the TSF on May 31, 2017. The last tailings slurry was discharged to the TSF on June 1, 2017. The filter press at the filter plant was cleaned and decommissioned on July 8, 2017. The completion of the entire cyanide circuit cleaning and rinse was on September 22, 2017. No more rinse water was sent to the TSF after September 22, 2017. Marlin anticipates that the residual water currently in the TSF will evaporate during the dry seasons.

In June 2017, Goldcorp rinsed the Leach, CCD, Merrill Crowe circuits in a closed loop for 15 days. The leach tanks were rinsed with fresh water and lime. The CCD tanks were rinsed with pressurized fresh water. Rinse solution was sent to the Detox tank. Sludge from the tanks was sent to the thickener and then to the Detox tank. The Detox tanks were the last tanks to be rinsed. This rinse water was sent to the TSF.

In order to determine the effectiveness of rinsing, samples were taken at the pregnant solution tank, the process water tank, leach tank 7, cyanide recovery thickener, wash water storage tank, and Detox tanks 1 and 2 for WAD, Free and Total cyanide concentrations. The auditor reviewed the analytical data and verified that the WAD cyanide concentrations were below 0.5 mg/l.

Goldcorp did not consider the filters as a candidate for rinsing because the filtration circuit followed the Cyanide Destruction Circuit during normal operation.

Based on the analytical data, the site inspection and interviews with the Production Plant Manager, Marlin has decommissioned the process circuit.

---

Goldcorp – Marlin Mine  
Name of Operation

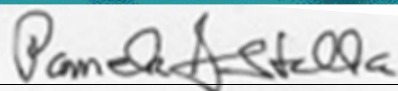
  
Signature of Lead Auditor

December 15, 2017  
Date

**Pamela Stella Environmental Mining Services LLC**

**Tailing Storage Facility**

Marlin used an INCO/SO2 treatment process to treat the slurry to below 0.5 mg/L WAD cyanide prior to deposition in the TSF. The term “cyanide facilities” is defined in the Definitions and Acronyms document on the ICMI web site as “A storage, production, waste management or regeneration unit for managing cyanide or cyanide-containing process solution,” Since the Code defines a processes solution as *any solution with 0.5 mg/l WAD cyanide or greater* the TSF is not a cyanide facility according to the ICMI.

One of the first steps to preparing the TSF for closure was to reduce the water stored in the TSF. In 2014 Goldcorp constructed a concrete closure spillway to discharge excess rainwater that had accumulated in the TSF. Diversion channels were built on either side of the TSF in 2015 to reduce the amount of water reporting to the facility.

The only open waters observed on site during the field component of this ICMC *Applicability Determination for Closure Audit*, was residual rinse water from the rinsing of the process plant and meteoric water within the TSF and the seepage toe collection pond. Marlin sampled open water at monitoring locations at the spillway discharge and the seepage toe collection pond. Monthly Free cyanide concentrations in the seepage toe collection pond from January 2015 to June 23, 2017 were all <0.01 mg/l.

Goldcorp started the plant rinse operations and releasing the residual rinse water to the TSF on May 31, 2017. The last tailings slurry was discharged to the TSF on June 1, 2017. The last rinse water from the plant decommissioning was sent to the TSF on September 22, 2017. Marlin anticipates that the residual water currently in the TSF will evaporate during the dry seasons and allow placement of a cover.

Marlin collects twelve-hour composite samples monthly at a surface water sampling location immediately downstream of the spillway discharge point at Quebrada Seca. Free cyanide

---

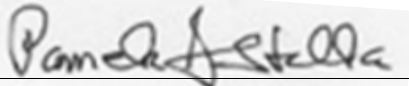
Goldcorp – Marlin Mine		December 15, 2017
Name of Operation	Signature of Lead Auditor	Date
<b>Pamela Stella Environmental Mining Services LLC</b>		
Page 22 of 58		

concentrations at this location have been below 0.01 mg/l since November 2016. Therefore, direct discharge from the TSF does not present a risk to the environment (aquatic life or wildlife).

Marlin has also established sampling stations downstream of the discharge point from the TSF spillway to the Quebrada Seca. One sampling station is located approximately 3 kilometers downstream of the TSF in Quebrada Seca before it joins the Quivichil River. It is the surface water point of compliance for Marlin's discharge to surface water and is sampled quarterly. Free cyanide concentrations from May 2016 to May 2017 have all been below 0.01 mg/l.

Another quarterly sampling point is located downstream of SW3 and downstream of the confluence of Quebrada Seca with the Quivichil River. Free cyanide concentration from May 2016 to May 2017 have all been below 0.01 mg/l.

Another surface water sampling point is located at the seepage collection pond downstream of the TSF embankment. It is currently a pool of water that supports vegetative and aquatic life. Goldcorp personnel indicated that the pond contains aquatic life (i.e., frogs), dragonflies and is a feeding pond for migratory birds. Monthly analytical data results for free cyanide were all less than 0.01 mg/l since January 2015.

The water quality data demonstrate that cyanide concentrations in surface water immediately downgradient of the tailings facility do not exceed the ICMC surface water quality standard for free cyanide (0.022 mg/L). Direct discharge from the TSF does not present a risk to the environment (aquatic life or wildlife). Also the data demonstrate that indirect seepage from the tailings has not presented a risk to the environment (aquatic life) because of its lack of cyanide content.

Based on the analytical data, the site inspection and interviews with the Production Plant Manager and the Water Quality and Laboratory Chief, Marlin has decommissioned the TSF.

---

Goldcorp – Marlin Mine  
Name of Operation

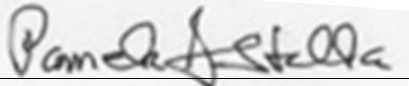
  
Signature of Lead Auditor  
**Pamela Stella Environmental Mining Services LLC**

December 15, 2017  
Date

**0.6 AUDITOR INFORMATION****Audit Company:** Pamela Stella Environmental Mining Services LLC**Audit Team Leader:** Pamela J. Stella, CEA**Address:** 10592 Harebell Run, Littleton, Co 80125**Contact Information:** Telephone +720-369-3437

Email: pamelajstella@msn.com

**Audit Dates:** September 24-28, 2017

I attest that I meet the criteria for knowledge, experience and conflict of interest for Code Verification Audit Team Leader, established by the International Cyanide Management Institute and that all members of the audit team meet the applicable criteria established by the International Cyanide Management Institute for Code Verification Auditors.

I attest that this Audit Report accurately describes the findings of the verification audit. I further attest that the verification audit was conducted in a professional manner in accordance with the International Cyanide Management Institute for Gold Mining Verification Protocol and using standard and accepted practices for health, safety and environmental audits.

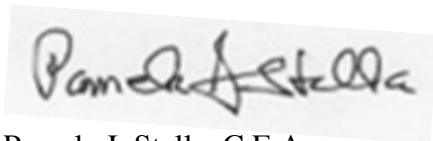

Pamela J. Stella, C.E.A

Lead Auditor and Gold Mining Technical Expert Auditor

Pamela Stella Environmental Mining Services LLC

---

Goldcorp – Marlin Mine  
Name of Operation

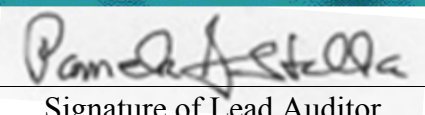

Signature of Lead Auditor  
**Pamela Stella Environmental Mining Services LLC**

December 15, 2017  
Date



**0.7 AUDIT FINDINGS**

ICMC APPLICABILITY DETERMINATION

- The operation is:
  - not subject to
  - subject to
 the International Cyanide Management Code

This *Applicability Determination for Closure Audit* was conducted following decommissioning of the Marlin cyanide facilities. Accordingly, the auditor determined that Goldcorp has successfully decommissioned the Marlin cyanide facilities in accordance with the ICMC definition for *Decommissioning* and that cyanide facilities and residual cyanide reagents no longer exist on site. Therefore, the Marlin operation is not subject to the ICMC.

This audit report documents the evidence supporting this finding for each ICMC Principle and Standard of Practice and demonstrates that the risks related to cyanide have been minimized to the point that all ICMC Principles and corresponding Standards of Practice provided in the ICMI Gold Mining Operations Verification Protocol (2016) no longer apply to the Marlin Mine. Because the Marlin Mine was recently recertified in May 2016 as being in full compliance with the Code, this final audit serves exclusively to verify that the Marlin Mine is no longer subject to the Code rather than to verify that the operation has or is meeting all of the Code Principles and Standards of Practice.

Goldcorp – Marlin Mine  
Name of Operation

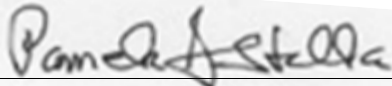
  
Signature of Lead Auditor

December 15, 2017  
Date

**Pamela Stella Environmental Mining Services LLC**

**SUMMARY AUDIT REPORT****1.0 PRODUCTION**

***Encourage responsible cyanide manufacturing by purchasing from manufacturers who operate in a safe and environmentally protective manner.***

**Standard of Practice 1.1**

***Purchase cyanide from manufacturers employing appropriate practices and procedures to limit exposure of their workforce to cyanide and to prevent releases of cyanide to the environment.***

The operation is:             not subject to  
    subject to  
   Standard of Practice 1.1

*Discuss the basis for this Finding/Deficiencies Identified:*

This ICMC Standard of Practice is not applicable to the Marlin Mine because the operation no longer purchases cyanide for use in the recovery of gold and no longer stores cyanide on site.

On April 28, 2017, Transportes Piman S.A. transported the last sodium cyanide to Marlin. The material shipped totaled approximately 60 tons of sodium cyanide. Auditor reviewed Purchase Order, bill of lading, and chain-of-custody documentation containing the serial number for each Intermediate Bulk Container (IBC).

During the field component of this ICMC *Applicability Determination for Closure Audit*, the auditor inspected the Cyanide Storage Warehouse and verified that it was completely empty. Goldcorp personnel stated that there has never been an IBC punctured during offloading or transporting to the cyanide mix area. Additionally, Goldcorp personnel indicated that no IBC boxes (empty or full) exist on site. Empty cyanide boxes are incinerated on site. Auditor

---

Goldcorp – Marlin Mine  
Name of Operation

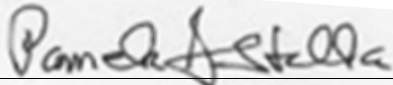
  
Signature of Lead Auditor

December 15, 2017  
Date

**Pamela Stella Environmental Mining Services LLC**

interview with Marlin’s Materials Manager, confirmed that cyanide is no longer produced for Marlin.

**2.0 TRANSPORTATION**

*Protect communities and the environment during cyanide transport.*

**Standard of Practice 2.1**

*Establish clear lines of responsibility for safety, security, release prevention, training and emergency response in written agreements with producers, distributors and transporters.*

The operation is:             not subject to  
    subject to  
   Standard of Practice 2.1

*Discuss the basis for the Finding/Deficiencies Identified:*

This ICMC Standard of Practice is not applicable to the Marlin Mine because the operation no longer uses cyanide at the site for the recovery of gold and cyanide is no longer transported to the site.

As discussed under ICMC Standard of Practice 1.1 above, on April 28, 2017, Transportes Piman S.A. transported the last shipment of sodium cyanide to Marlin. The sodium cyanide shipment was 60-one ton intermediate bulk containers (IBC).

Auditor reviewed bill of lading, and chain-of-custody documentation containing the serial number for each IBC. During the field component of this ICMC *Applicability Determination for Closure Audit*, the auditor inspected the Cyanide Storage Warehouse and verified that it was completely empty. Additionally, Goldcorp personnel indicated that no IBCs (empty or full) exist on site.

Goldcorp – Marlin Mine  
Name of Operation

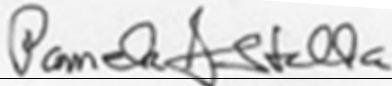
  
Signature of Lead Auditor

December 15, 2017  
Date

**Pamela Stella Environmental Mining Services LLC**

**Standard of Practice 2.2**

***Require that cyanide transporters implement appropriate emergency response plans and capabilities, and employ adequate measures for cyanide management.***

The operation is:             not subject to  
    subject to  
   Standard of Practice 2.2

*Discuss the basis for the Finding/Deficiencies Identified:*

This ICMC Standard of Practice is not applicable to the Marlin Mine because the operation no longer uses cyanide at the site for the recovery of gold and cyanide is no longer transported to the site.

On April 28, 2017, Transportes Piman S.A. transported the last shipment of sodium cyanide to Marlin. The sodium cyanide shipment was 60-one ton intermediate bulk containers (IBC). Auditor reviewed bill of lading, and chain-of-custody documentation containing the serial number for each IBC.

**3.0 HANDLING AND STORAGE**

***Protect workers and the environment during cyanide handling and storage.***

**Standard of Practice 3.1**

***Design and construct unloading, storage and mixing facilities consistent with sound, accepted engineering practices and quality control and quality assurance procedures, spill prevention and spill containment measures.***

The operation is:             not subject to  
    subject to  
   Standard of Practice 2.1

*Discuss the basis for this Finding/Deficiencies Identified:*

---

Goldcorp – Marlin Mine  
Name of Operation

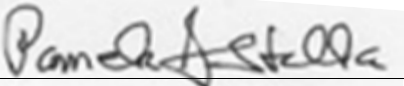
  
Signature of Lead Auditor  
**Pamela Stella Environmental Mining Services LLC**

December 15, 2017  
Date

This ICMC Standard of Practice is not applicable to the Marlin Mine because the operation no longer uses cyanide at the site for the recovery of gold and cyanide is no longer stored or mixed on site. The facilities previously used for the unloading, storage and mixing of cyanide have been decommissioned.

On May 30, 2017 the last mix of cyanide occurred using the last of the IBC boxes. On June 13, 2017, Goldcorp emptied the Sodium Cyanide Mixing Tank and the Sodium Cyanide Distribution Tank and began neutralizing, decontaminating and washing the two tanks using caustic soda and sodium hypochlorite. Goldcorp followed its written procedure, "*Cleaning of Process Plant Tanks*" (July 2015) and the September 2016 Process Plant Closure Plan Report which include the detailed steps implemented.

During emptying, the tanks were drained to the concrete containment sump and the solution was pumped to the Grinding Thickener. After rinsing repeatedly for ten cycles, using the tank agitators to thoroughly mix the neutralizing solution, the residual rinse solution was pumped to the leach tank 1 and combined with the residual rinse solution from the other process circuits.

On June 13, 2017, Goldcorp completed rinsing both tanks and the sumps and concrete containment areas, thus ending decommissioning activities for the Cyanide Preparation Area.

During the field component of this ICMC *Applicability Determination for Closure Audit*, the auditor inspected the Cyanide Storage Warehouse and the Cyanide Preparation Area. The auditor verified that the warehouse was completely empty and free of residual sodium cyanide. The Closure Manager indicated that following removal of the last IBC boxes, the concrete floor inside the warehouse was swept. Marlin did not rinse the warehouse floor because there never has been any cyanide spills in the warehouse. The auditor also visually verified that the facilities previously utilized for the mixing and storage of sodium cyanide at the Cyanide Preparation Area,

---

Goldcorp – Marlin Mine  
Name of Operation

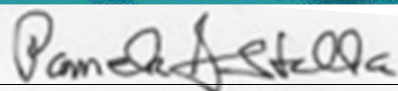
  
Signature of Lead Auditor

December 15, 2017  
Date

**Pamela Stella Environmental Mining Services LLC**

including tanks, feed hoppers, pumps, valves, pipes, concrete containments and appurtenances were empty and free of residual cyanide particles and encrustations.

**Standard of Practice 3.2**

*Operate unloading, storage and mixing facilities using inspections, preventive maintenance and contingency plans to prevent or contain releases and control and respond to worker exposures.*

The operation is:      not subject to  
                                   subject to  
                                  Standard of Practice 3.2

*Discuss the basis for this Finding/Deficiencies Identified:*

This ICMC Standard of Practice is not applicable to the Marlin Mine because the operation no longer uses cyanide at the site for the recovery of gold and cyanide is no longer stored or mixed on site. The facilities previously used for the unloading, storage and mixing of cyanide have been decommissioned. The last shipment of cyanide to Marlin was on April 28, 2017. On May 30, 2017, Marlin mixed the last cyanide.

During the field component of this ICMC *Applicability Determination for Closure Audit*, the auditor inspected the Cyanide Storage Warehouse and the Cyanide Preparation Area. The auditor verified that the warehouse was completely empty and free of residual sodium cyanide.

All box components were transferred to the onsite incinerator and burned according to a written procedure (i.e., “MA-PRO-34 Incinerator Operating Procedure”). An identification number to ensure that all were incinerated tracked each box.

Goldcorp – Marlin Mine  
Name of Operation

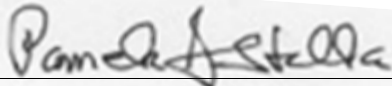
  
Signature of Lead Auditor

December 15, 2017  
Date

**Pamela Stella Environmental Mining Services LLC**

**4.0 OPERATIONS**

***Manage cyanide process solutions and waste streams to protect human health and the environment.***

**Standard of Practice 4.1**

***Implement management and operating systems designed to protect human health and the environment including contingency planning and inspection and preventive maintenance procedures.***

The operation is:      not subject to  
                                   subject to  
Standard of Practice 4.1

*Discuss the basis for the Finding/Deficiencies Identified:*

This ICMC Standard of Practice is not applicable to the Marlin Mine because the operation no longer uses cyanide at the site for the recovery of gold and cyanide is no longer stored or mixed on site. The process facilities previously used for the unloading, storage and mixing of cyanide and for the recovery of gold (i.e., the Marlin cyanide facilities) have been decommissioned and are no longer operating. The cyanide facilities that were active prior to decommissioning included the following:

- . Cyanide mixing and storage tanks
- . Grinding circuit
- . Intensive leach circuit (Gekko – inactive since 2007)
- . Mill thickener
- . Leach tanks
- . Counter-current decant (CCD) tanks
- . Merrill - Crowe plant
- . Cyanide Neutralization circuit (i.e., INCO/SO2 treatment).
- . Tailings storage facilities (TSF) including the seepage collection pond at the toe of the embankment

Goldcorp – Marlin Mine  
Name of Operation

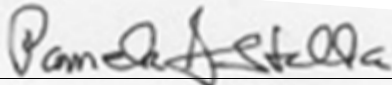
  
Signature of Lead Auditor

December 15, 2017  
Date

**Pamela Stella Environmental Mining Services LLC**

- . Water treatment plant (WTP) associated with the TSF
- . Cyanide warehouse and small interim storage shed at the mixing area
- . Diversion channels on either side of the TSF
- . Associated concrete and lined secondary containment structures, sumps, process solution transfer pipes, valves, and pumps.

Please refer to **Section 0.5.3** of this audit report for a description of the activities that Goldcorp completed to decommission the Marlin cyanide facilities. As verification that the cyanide facilities have been fully decommissioned, Goldcorp provided analytical results demonstrating that WAD cyanide concentrations of residual rinse solutions within the process circuits, the TSF, the spillway and the seepage collection pond were below 0.5 mg/L following the detoxification and neutralization rinse cycles. Following confirmation testing and regulatory approval, Goldcorp released the residual rinse water through the spillway to a natural drainage.

During the field component of this ICMC *Applicability Determination for Closure Audit*, the auditor inspected the above-listed facilities. The auditor verified that the Cyanide Storage Warehouse was completely empty and free of residual sodium cyanide. The auditor also visually verified that the above-listed process areas and circuits, including tanks, feed hoppers, pumps, valves, pipes, concrete containments and appurtenances were empty of solution and free of residual cyanide particles and encrustations.

The only open or stored water observed on site during the field component of this audit, was meteoric water and residual rinse water in the TSF and seepage water in the seepage collection pond.

Marlin inspects the diversion channels monthly. In addition, Marlin conducts monthly bathymetry measurements, weekly settlement monument monitoring, weekly piezometer

Goldcorp – Marlin Mine  
Name of Operation

  
Signature of Lead Auditor

December 15, 2017  
Date

**Pamela Stella Environmental Mining Services LLC**



monitoring, and real-time accelerometer monitoring. The Engineer of Record conducts annual dam inspections.

Although the Marlin cyanide facilities have been decommissioned and are no longer operating, the mine continues to employ 8 generators for a total capacity of 10.5 MW, which was sufficient to run the entire process plant. During the field component of this ICMC *Applicability Determination for Closure Audit*, the generators were running intermittently due to temporary line power outages.

**Standard of Practice 4.2**

***Introduce management and operating systems to minimize cyanide use, thereby limiting concentrations of cyanide in mill tailings.***

The operation is:      not subject to  
                                   subject to  
Standard of Practice 4.2

*Discuss the basis for this Finding/Deficiencies Identified:*

This ICMC Standard of Practice is not applicable to the Marlin Mine because the operation no longer uses cyanide at the site for the recovery of gold and cyanide is no longer stored or mixed on site. The process facilities previously used for the unloading, storage and mixing of cyanide and for the recovery of gold (i.e., the Marlin cyanide facilities) have been decommissioned and are no longer operating.

**Standard of Practice 4.3**

***Implement a comprehensive water management program to protect against unintentional releases.***

The operation is:      not subject to

Goldcorp – Marlin Mine  
Name of Operation

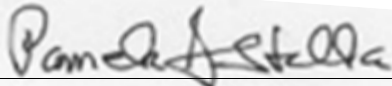
  
Signature of Lead Auditor

December 15, 2017  
Date

**Pamela Stella Environmental Mining Services LLC**

subject to  
Standard of Practice 4.3

*Discuss the basis for the Finding/Deficiencies Identified:*

This ICMC Standard of Practice is not applicable to the Marlin Mine because the operation no longer uses cyanide at the site for the recovery of gold and cyanide is no longer stored or mixed on site. The process facilities previously used for the unloading, storage and mixing of cyanide and for the recovery of gold (i.e., the Marlin cyanide facilities) have been decommissioned and are no longer operating.

Marlin has developed a comprehensive and probabilistic water balance. This is the same GoldSim model that was evaluated and found compliant in the initial certification audit in 2009 and the recertification audits in 2013 and 2016.

The GoldSim model was originally developed by a third party qualified consultant company in 2007. Marlin has updated the model continuously since that time. During operations, the model was updated monthly with presentations to communicate the results to staff and management. Marlin also prepared annual water balance reports that the auditors reviewed to verify compliance in the 2016 re-certification audit.

The model is comprehensive in that it contains the appropriate inflows and outflows. The inflows are precipitation, runoff, tailings, treated sewage, seepage return flows, and pit dewatering (wet season only). The outflows are natural evaporation, forced evaporation, spillway discharge, water treatment plant discharge, seepage losses, and diverted run-on. Since the re-certification audit in 2013, Marlin has made the following changes to the model to reflect the then ongoing preparations for closing the TSF:

---

Goldcorp – Marlin Mine  
Name of Operation

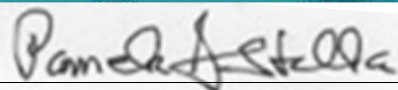
  
Signature of Lead Auditor

December 15, 2017  
Date

**Pamela Stella Environmental Mining Services LLC**

- Sending the dewatering water from the underground mine to the WTP for discharge to the environment rather than to the TSF.
- Forced evaporation (turbomisters) was installed in in 2014.
- Run-on diversion channels were constructed on both sides of the TSF to divert run-on around the TSF.

The design criterion for containment at the TSF is the 100-year, 24-hour storm event (335 mm). The Marlin water balance model considers the precipitation falling directly onto the TSF, and stormwater runoff between the diversion structures and the TSF. The model was updated to reflect the new diversion channels built in 2015.

System losses simulated by Marlin’s model included reclaim of tailings water back to the mill for operating purposes, slurry water that is entrained in the tailings, evaporation (forced and natural), seepage collection (returned to the TSF), and allowable discharges of treated process water through the decant system and the WTP.

Marlin conducts inspections and automated monitoring to implement the water balance and prevent overtopping of the TSF. Plant staff conducts daily inspections of the TSF and environmental staff conducts monthly inspections. Marlin installed a level sensor in 2013 that allowed continuous, real-time water level monitoring for the TSF. Other monitoring activities include:

- Piezometers (weekly)
- Settlement monuments (weekly)
- Bathymetric surveys (monthly)
- Run-on diversion inspections (random, during planned general inspections)
- Annual dam inspections by the Engineer of Record.

Goldcorp – Marlin Mine  
Name of Operation

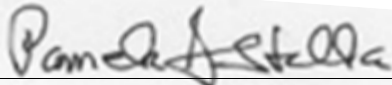
  
Signature of Lead Auditor

December 15, 2017  
Date

**Pamela Stella Environmental Mining Services LLC**

The only open or stored water observed on site during the field component of this audit, was meteoric water within the TSF and the seepage collection pond. The WAD cyanide concentrations in the TSF were below 0.5 mg/l. Goldcorp has not released tailings into the TSF since June 1, 2017. Water in the TSF is currently being discharged because the WAD cyanide concentration is less than 0.01 mg/l and is allowed by the Guatemalan government. It was the rainy season during this audit and there was meteoric water in the TSF. This water is expected to evaporate during the dry season.

The auditor reviewed the water balance with Marlin's Supervisor of Civil Works, to verify the remaining freeboard in the TSF. The TSF design criteria is for 100-year 24-hour storm event plus 2 m freeboard. At the time of this audit, the remaining freeboard in the TSF was 4.8 meters.

As part of the mine closure plan, Goldcorp constructed a new surface water diversion system to route upgradient runoff from the northwest and southeast around the reclaimed process area and the TSF. Completion of the diversion system was in 2015. The diversion channels were designed for a 10-year 24-hour storm event of 81mm and a 100-year 24-hour storm event of 124 mm. The spillway was designed for a 24-hour probable maximum precipitation of 1330 mm and a 100-year 24-hour storm event of 350 mm.

The diversion channels and spillway will capture and collect stormwater from natural drainages upstream of the mine site and convey these flows around mine facilities. This water will exit the mine site downgradient of the mine infrastructure and discharge into existing natural drainages of Quebrada Seca that flows to the Quivichil River.

#### **Standard of Practice 4.4**

*Implement measures to protect birds, other wildlife and livestock from adverse effects of cyanide process solutions.*

---

Goldcorp – Marlin Mine  
Name of Operation

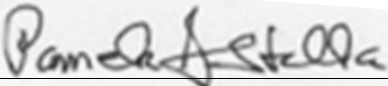
  
Signature of Lead Auditor  
**Pamela Stella Environmental Mining Services LLC**

December 15, 2017  
Date

The operation is:      not subject to  
                                   subject to  
                                  Standard of Practice 4.4

*Discuss the basis for the Finding/Deficiencies Identified:*

This ICMC Standard of Practice is not applicable to the Marlin Mine because the operation no longer uses cyanide at the site for the recovery of gold and cyanide is no longer stored or mixed on site. The process facilities previously used for the unloading, storage and mixing of cyanide and for the recovery of gold (i.e., the Marlin cyanide facilities) have been decommissioned and are no longer operating.

The only open waters observed on site during the field component of this ICMC *Applicability Determination for Closure Audit*, was residual rinse water from the rinsing of the process plant and meteoric water within the TSF and the seepage toe collection pond. Marlin sampled open water at monitoring locations at the discharge through the spillway) and at the seepage toe collection pond.

Goldcorp started the plant rinse operations and releasing the residual rinse water to the TSF on May 31, 2017. The last tailings slurry was discharged to the TSF on June 1, 2017. The filter press at the filter plant was cleaned and decommissioned on July 8, 2017. The completion of the entire cyanide circuit cleaning and rinse was on September 22, 2017. No more rinse water was sent to the TSF after September 22, 2017. Marlin anticipates that the residual water currently in the TSF will evaporate during the dry seasons.

Monthly WAD CN analytical results at the discharge at the spillway from April 2015 to May 2017 ranged from 0.31 to 0.03 mg/l in May 2017. The WAD cyanide concentrations at the seepage toe collection pond from May 2016 to June 2017 were all <0.01 mg/l. Analytical results demonstrate that the open waters at Marlin are well below 50 mg/l WAD cyanide and therefore

---

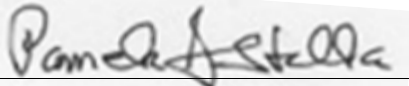
Goldcorp – Marlin Mine		December 15, 2017
Name of Operation	Signature of Lead Auditor	Date
<b>Pamela Stella Environmental Mining Services LLC</b>		
Page 37 of 58		

there is no potential for cyanide-related impacts to birds, other wildlife and livestock from open waters.

Marlin does not have a heap leach pad, so the issue of ponding and overspray is not applicable.

**Standard of Practice 4.5**

***Implement measures to protect fish and wildlife from direct and indirect discharges of cyanide process solutions to surface water.***

The operation is:      not subject to  
                                   subject to  
                                  Standard of Practice 4.5

*Discuss the basis for the Finding/Deficiencies Identified:*

This ICMC Standard of Practice is not applicable to the Marlin Mine because the cyanide facilities have been decommissioned and, as discussed below, Goldcorp has demonstrated that direct discharge to the surface water has free cyanide concentration less than 0.01 mg/l. Currently, the only direct discharge to surface water is meteoric water and residual rinse water from the TSF. This discharge is through the spillway into Quebrada Seca, an intermittent tributary to the Quivichil River. During operations, Marlin had two direct discharges to surface water. The TSF received slurry from the INCO/SO<sub>2</sub> cyanide destruction circuit. One discharge was from the decant pond via the spillway. The TSF discharge typically occurred only in the wet months from May to October during operation. The second discharge was treated water from the water treatment plant (WTP). The WTP received water from the underground mine and the recycled TSF decant pool for treatment via oxidation by hydrogen peroxide followed by clarification and carbon columns. The WTP discharged typically occurred in the dry months from November to April. The WTP was rinsed and closed as part of the operational closure activities and is no longer operational. Milling and processing

Goldcorp – Marlin Mine  
Name of Operation

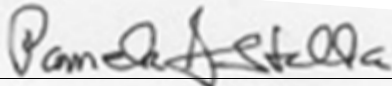
  
Signature of Lead Auditor

December 15, 2017  
Date

**Pamela Stella Environmental Mining Services LLC**

ceased in May 2017 and tailings have not been sent to the TSF since June 1, 2017 therefore there is no longer a tailings decant pond.

Marlin has established a water sampling station immediately downstream of the spillway discharge point at Quebrada Seca and collects twelve-hour composite samples monthly at this station. Free cyanide concentrations at this station have been below 0.01 mg/l since November 2016. Therefore, direct discharge from the TSF does not present a risk to the environment (aquatic life or wildlife).

Marlin has established sampling stations downstream of the discharge point from the TSF spillway to the Quebrada Seca. Sampling station SW3 is located approximately 3 kilometers downstream of the TSF in Quebrada Seca before it joins the Quivichil River. It is the surface water point of compliance for Marlin's discharge to surface water. Free cyanide concentrations from May 2016 to May 2017 have all been below 0.01 mg/l, the laboratory detection limit. SW3 is sampled quarterly.

Another surface water sampling point is located at the seepage collection pond downstream of the TSF embankment. It is currently a pool of water that supports vegetative and aquatic life. Goldcorp personnel indicated that the pond contains aquatic life (i.e., frogs), dragonflies and is a feeding pond for migratory birds. Monthly analytical data results for free cyanide were all less than 0.01 mg/l since January 2015.

The water quality data demonstrate that cyanide concentrations in surface water immediately downgradient of the tailings facility do not exceed the ICMC surface water quality standard for free cyanide (0.022 mg/L).

---

Goldcorp – Marlin Mine  
Name of Operation

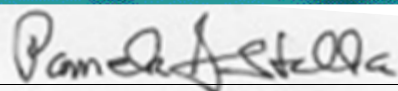
  
Signature of Lead Auditor

December 15, 2017  
Date

**Pamela Stella Environmental Mining Services LLC**

Direct discharge from the TSF does not present a risk to the environment (aquatic life or wildlife). Also the data demonstrate that indirect seepage from the tailings has not presented a risk to the environment (aquatic life) because of its lack of cyanide content.

Direct discharge from the TSF does not present a risk to the environment (aquatic life or wildlife). Also the data demonstrate that indirect seepage from the tailings has not presented a risk to the environment (aquatic life) because of its lack of cyanide content.

Marlin does not have an indirect discharge to surface water. The plant and TSF are located in the headwaters of the watershed of the Quebrada Seca and therefore the embankment for the TSF is the collection point for any surface or subsurface pathways. The TSF was designed to reduce the potential for indirect discharges (i.e., seepage) from the TSF as stated in the 2016 re-certification audit:

“The embankment has an inclined, low-permeability core, a grout curtain to control seepage through the embankment foundation, internal drainage and a dam seepage collection system. The TSF is constructed over a bedrock foundation. The TSF is constructed with a main dam across the drainage and a saddle berm along the eastern flank. The main dam is constructed with a compacted low permeability core keyed into bedrock with a trench. The low permeability core is buttressed on the upstream slope by a toe cofferdam and rock shell fill. The low permeability core is buttressed on the downstream slope by a vertical rock filter drain, rock drain and rock shell fills. The vertical drain is connected at the base to a main drain that takes dam seepage out to a collection pond.”

**Standard of Practice 4.6**

*Implement measures designed to manage seepage from cyanide facilities to protect the beneficial uses of ground water.*

Goldcorp – Marlin Mine  
Name of Operation

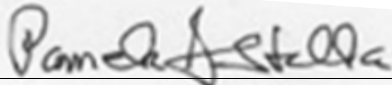
  
Signature of Lead Auditor

December 15, 2017  
Date

**Pamela Stella Environmental Mining Services LLC**



The operation is:  not subject to  
 subject to  
Standard of Practice 4.6

*Discuss the basis for the Finding/Deficiencies Identified:*

This ICMC Standard of Practice is not applicable to the Marlin Mine because the operation no longer uses cyanide at the site for the recovery of gold and cyanide is no longer stored or mixed on site. The process facilities previously used for the unloading, storage and mixing of cyanide and for the recovery of gold (i.e., the Marlin cyanide facilities) have been decommissioned and are no longer operating. Marlin has implemented water management measures to protect the beneficial uses of groundwater beneath and downgradient of the cyanide facilities.

During operations and decommissioning of the cyanide facilities Marlin used an INCO/SO2 treatment process to treat the tailings slurry and decommissioning rinse water to below 0.5 mg/L WAD cyanide prior to deposition in the TSF. Marlin also operated another treatment process that used oxidation by hydrogen peroxide followed by clarification and carbon columns.

The design and construction of the TSF provided water management measures to protect the groundwater beneath and downgradient of the TSF. The TSF has a phased earth and rockfill embankment. The embankment has an inclined, low-permeability core, a grout curtain to control seepage through the embankment foundation, internal drainage and a dam seepage collection system. The TSF is constructed over a bedrock foundation. The TSF is constructed with a main dam across the drainage and a saddle berm along the eastern flank.

The main dam is constructed with a compacted low permeability core keyed into bedrock with a trench. The low permeability core is buttressed on the upstream slope by a toe cofferdam and rock shell fill. The low permeability core is buttressed on the downstream slope by a vertical rock filter

Goldcorp – Marlin Mine  
Name of Operation

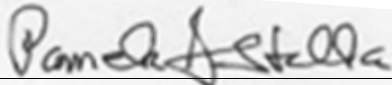
  
Signature of Lead Auditor

December 15, 2017  
Date

**Pamela Stella Environmental Mining Services LLC**

drain, rock drain and rock shell fills. The vertical drain is connected at the base to a main drain that takes dam seepage out to a collection pond. To limit seepage beneath the embankment and through the abutments, the grout curtain was installed to intercept zones of higher permeability foundation materials. The tailings design included detailed hydrogeologic characterization before and after the grouting program to define the permeability of the foundation and grout curtain.

The TSF embankment includes internal drainage to provide an engineered path to collect, route, and manage water infiltrating into, around, and through the dam. The drain system consists of a chimney drain installed along the downstream side of the dam's low permeability core and a main drain constructed along the valley bottom from the base of the chimney drain to a discharge point at the toe of the dam. A seepage collection pond, located at the toe of the TSF embankment, intercepts and stores seepage from this main drain. During operations the seepage collecting in the pond was pumped back to the TSF. Marlin is planning to stop pumping the pond water back to the TSF because the water quality in the pond indicates that there is no cyanide in the pond.

Marlin staff stated that there is no beneficial use for groundwater designated by the regulators, nor is there an applicable Guatemalan groundwater standard.

Marlin collects quarterly groundwater samples from 3 wells located downgradient of the TSF. All results for WAD and Total cyanide from these wells were non-detect at less than 0.001 mg/l from May 2016 to May 2017. Marlin has demonstrated that seepage from the TSF following decommissioning does not present a risk to groundwater quality.

Marlin did not use mill tailings as underground backfill during operations.

Groundwater monitoring data indicate that Marlin has not caused increases in concentrations of WAD cyanide in groundwater below or downgradient of the cyanide facilities, and therefore is not engaged in groundwater remediation to prevent further degradation or restore beneficial use.

---

Goldcorp – Marlin Mine  
Name of Operation

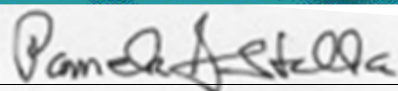
  
Signature of Lead Auditor

December 15, 2017  
Date

**Pamela Stella Environmental Mining Services LLC**

**Standard of Practice 4.7**

*Provide spill prevention or containment measures for process tanks and pipelines.*

The operation is:             not subject to  
    subject to  
   Standard of Practice 4.7

*Discuss the basis for the Finding/Deficiencies Identified:*

This ICMC Standard of Practice is not applicable to the Marlin Mine because the operation no longer uses cyanide at the site for the recovery of gold and cyanide is no longer stored or mixed on site. The process facilities previously used for the unloading, storage and mixing of cyanide and for the recovery of gold (i.e., the Marlin cyanide facilities) have been decommissioned and are no longer operating.

**Standard of Practice 4.8**

*Implement quality control/quality assurance procedures to confirm that cyanide facilities are constructed according to accepted engineering standards and specifications.*

The operation is:             not subject to  
    subject to  
   Standard of Practice 4.8

*Describe the basis for the Finding/Deficiencies Identified:*

This ICMC Standard of Practice is not applicable to the Marlin Mine because the operation no longer uses cyanide at the site for the recovery of gold and cyanide is no longer stored or mixed on site. The process facilities previously used for the unloading, storage and mixing of cyanide and for the recovery of gold (i.e., the Marlin cyanide facilities) have been decommissioned and

Goldcorp – Marlin Mine  
Name of Operation

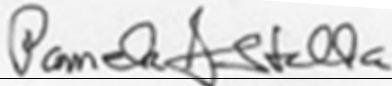
  
Signature of Lead Auditor

December 15, 2017  
Date

**Pamela Stella Environmental Mining Services LLC**

are no longer operating. Goldcorp has not constructed any new cyanide facilities or modified any existing cyanide facilities subsequent to the 2016 ICMC recertification audit.

**Standard of Practice 4.9**

***Implement monitoring programs to evaluate the effects of cyanide use on wildlife, surface and ground water quality.***

The operation is:      not subject to  
                                   subject to  
Standard of Practice 4.9

*Describe the basis for the Finding/Deficiencies Identified:*

This ICMC Standard of Practice is not applicable to the Marlin Mine because the operation no longer uses cyanide at the site for the recovery of gold and cyanide is no longer stored or mixed on site. The process facilities previously used for the unloading, storage and mixing of cyanide and for the recovery of gold (i.e., the Marlin cyanide facilities) have been decommissioned and are no longer operating.

Marlin has demonstrated that indirect seepage from the facilities during operation and following decommissioning does not present a risk to the environment (water quality and wildlife) because of its lack of cyanide content (see ICMC Standards of Practice 4.4, 4.5 and 4.6 above). Therefore, the written procedures developed by Goldcorp for monitoring activities, as documented in the ICMC Detailed Audit Report prepared for the 2016 ICMC recertification audit, no longer apply for purposes of the Code

Marlin has developed a monitoring plan, a quality assurance/quality control (QA/QC) plan, and standard operating procedures for discharge, surface water, and groundwater sampling. These procedures were followed to conduct the sampling of the surface water and groundwater monitoring points during decommissioning. The monitoring plan summarizes applicable

Goldcorp – Marlin Mine  
Name of Operation

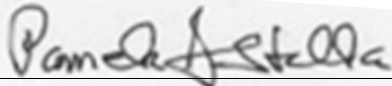
  
Signature of Lead Auditor

December 15, 2017  
Date

**Pamela Stella Environmental Mining Services LLC**

regulations, objectives, sampling locations, sampling frequencies, procedures, constituent lists, quality management, data management, and reporting. The QA/QC plan discusses field QA/QC samples, laboratory QA/QC samples, external quality control, and data validation. The standard operating procedures detail field parameters, water levels, flow rates, sample labeling, containerization, filtration, preservation, storage, holding times, shipping, and chain-of-custody completion. Completed chain of custody forms were reviewed by the Auditor.

Although all cyanide facilities at Marlin has been decommissioned they are still currently monitoring for cyanide at their discharge point (i.e., the TSF spillway) and in surface water and groundwater downgradient of the TSF.

Marlin no longer monitors for wildlife at the site because all cyanide facilities have been decommissioned.

## **5.0 DECOMMISSIONING**

***Protect communities and the environment from cyanide through development and implementation of decommissioning plans for cyanide facilities.***

### **Standard of Practice 5.1**

***Plan and implement procedures for effective decommissioning of cyanide facilities to protect human health, wildlife and livestock.***

The operation is:       not subject to  
                                   subject to  
                                  Standard of Practice 5.1

*Describe the basis for the Finding/Deficiencies Identified:*

This ICMC Standard of Practice is not applicable to the Marlin Mine because the operation no longer uses cyanide at the site for the recovery of gold and cyanide is no longer stored or mixed on site. The process facilities previously used for the unloading, storage and mixing of cyanide

Goldcorp – Marlin Mine  
Name of Operation

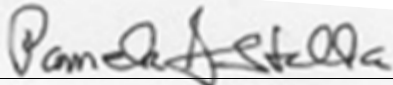
  
Signature of Lead Auditor

December 15, 2017  
Date

**Pamela Stella Environmental Mining Services LLC**

and for the recovery of gold (i.e., the Marlin cyanide facilities) have been decommissioned and are no longer operating.

The Marlin Closure Plan (dated 2014) presents the general closure activities proposed for the entire site and describes measures to fully close the mine facilities, process facilities and the infrastructure. Section 5.3 specifically discusses the activities needed for Code compliance, such as:

- Remaining cyanide will likely be used, but if not, it will be returned to the vendor.
- Decontamination of equipment and structural will consist of rinsing with oxidants and/or triple rinsing until the concentration of WAD cyanide is less than 0.5 mg/l.
- Rinse solutions will be sent to the TSF for disposal.

Chapter 6 covers the TSF, including the seepage collection pond at the toe of the embankment, the piping to and from the plant, and valves, pumps, barges, etc. Section 6.4 specifically discusses the activities needed for Code compliance:

- Removal of the excess water on the surface of the TSF via treatment in the Water Treatment Plant (WTP) for the TSF with subsequent discharge to the nearby creeks when the concentration of free cyanide less than 0.022 mg/l.
- Decontamination of the piping, pumps, valves, barges, etc. will consist of rinsing with oxidants and/or triple rinsing until the concentration of WAD cyanide is less than 0.5 mg/l.

Refer to Section 0.5.2 of this audit report for a summary of the measures presented in the Closure Plan for closure of the process facilities.

Goldcorp prepared the *Process Plant Closure Plan (Cleaning)*(dated September 2016), which describes the actual decommissioning activities that Goldcorp conducted to treat, neutralize or otherwise manage cyanide and cyanide containing process solutions remaining in storage and

Goldcorp – Marlin Mine  
Name of Operation

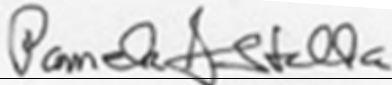
  
Signature of Lead Auditor

December 15, 2017  
Date

**Pamela Stella Environmental Mining Services LLC**

process facilities in preparation for closure. Goldcorp submitted this Closure Plan to the Guatemalan government.

The Plan describes the decommissioning activities that Goldcorp planned to implement for decontaminating and decommissioning the plant. The only decommissioning activity remaining at that time of this audit was dismantling and demolition and reclamation of the TSF

The 2014 closure plan had a broader mine-wide closure schedule that covers the period from 2016 to 2019. The schedule is detailed to the monthly level and activities are tied to specific dates. Marlin also produced a detailed schedule for cleaning of the process plant. Refer to Standard of Practice 4.1 above for a summary of the decommissioning activities completed by Goldcorp for the Marlin cyanide facilities as presented in the Decontamination Report.

**Standard of Practice 5.2**

*Establish an assurance mechanism capable of fully funding cyanide-related decommissioning activities.*

The operation is:      not subject to  
                                   subject to  
                                  Standard of Practice 5.2

*Describe the basis for this Finding/Deficiencies Identified:*

This ICMC Standard of Practice is not applicable to the Marlin Mine. Nonetheless, as documented in the ICMC Detailed Audit Report prepared for the 2016 ICMC re-certification audit, Goldcorp developed an estimate of the cost to fully fund third party implementation of the cyanide-related decommissioning measures as identified in its Closure Plan.

Marlin internally developed a cost model for mine-wide closure. The cost estimate includes direct costs for construction, as well as add-on percentages for third party engineering design and

---

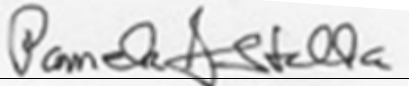
Goldcorp – Marlin Mine		December 15, 2017
Name of Operation	Signature of Lead Auditor	Date
<b>Pamela Stella Environmental Mining Services LLC</b>		
Page 47 of 58		

contract administration. The cost estimate is based on quoted rates for third party contractors and consultants.

As documented in the ICMC Detailed Audit Report prepared for the 2016 ICMC recertification audit Marlin has established closure bonding with the Guatemalan government, specifically the Ministry of Natural Resources. The auditors for the 2016 ICMC recertification audit reviewed three governmental resolutions showing that the bonding had been accepted. Marlin also provided current copies of the bonds showing that they have been renewed as needed; all bonds were current at the time of the site visit. The total amount of is in excess of the estimate for cyanide decommissioning (cyanide decontamination activities, water treatment, and disposal of wastes). Therefore, Marlin has established a financial mechanism approved by the applicable jurisdiction.

**6.0 WORKER SAFETY**

*Protect workers’ health and safety from exposure to cyanide.*

**Standard of Practice 6.1**

*Identify potential cyanide exposure scenarios and take measures as necessary to eliminate, reduce and control them.*

The operation is:             not subject to  
    subject to  
Standard of Practice 6.1

*Describe the basis for the Finding/Deficiencies Identified:*

This ICMC Standard of Practice is not applicable to the Marlin Mine because the operation no longer uses cyanide at the site for the recovery of gold and cyanide is no longer stored or mixed on site. The process facilities previously used for the unloading, storage and mixing of cyanide and for the recovery of gold (i.e., the Marlin cyanide facilities) have been decommissioned and are no longer operating.

Goldcorp – Marlin Mine  
Name of Operation

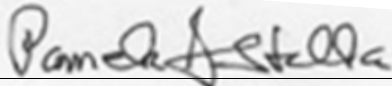
  
Signature of Lead Auditor

December 15, 2017  
Date

**Pamela Stella Environmental Mining Services LLC**



**Standard of Practice 6.2**

*Operate and monitor cyanide facilities to protect worker health and safety and periodically evaluate the effectiveness of health and safety measures.*

The operation is:  not subject to  
 subject to  
Standard of Practice 6.2

*Describe the basis for the Finding/Deficiencies Identified:*

This ICMC Standard of Practice is not applicable to the Marlin Mine because the operation no longer uses cyanide at the site for the recovery of gold and cyanide is no longer stored or mixed on site. The process facilities previously used for the unloading, storage and mixing of cyanide and for the recovery of gold (i.e., the Marlin cyanide facilities) have been decommissioned and are no longer operating. Therefore, Marlin does not need to operate and monitor cyanide facilities.

**Standard of Practice 6.3**

*Develop and implement emergency response plans and procedures to respond to worker exposure to cyanide.*

The operation is:  not subject to  
 subject to  
Standard of Practice 6.3

*Summarize the basis for this Finding/Deficiencies Identified:*

This ICMC Standard of Practice is not applicable to the Marlin Mine because the operation no longer uses cyanide at the site for the recovery of gold and cyanide is no longer stored or mixed on site. The process facilities previously used for the unloading, storage and mixing of cyanide

Goldcorp – Marlin Mine  
Name of Operation

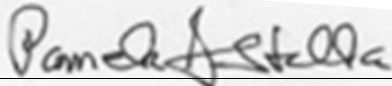
  
Signature of Lead Auditor

December 15, 2017  
Date

**Pamela Stella Environmental Mining Services LLC**

and for the recovery of gold (i.e., the Marlin cyanide facilities) have been decommissioned and are no longer operating. Therefore, Marlin does not need to implement emergency response plans and procedures to respond to worker exposure to cyanide.

**7.0 EMERGENCY RESPONSE**

*Protect communities and the environment through the development of emergency response strategies and capabilities.*

**Standard of Practice 7.1**

*Prepare detailed emergency response plans for potential cyanide releases.*

The operation is:             not subject to  
    subject to  
Standard of Practice 7.1

*Describe the basis for the Finding/Deficiencies Identified:*

This ICMC Standard of Practice is not applicable to the Marlin Mine because the operation no longer uses cyanide at the site for the recovery of gold and cyanide is no longer stored or mixed on site. The process facilities previously used for the unloading, storage and mixing of cyanide and for the recovery of gold (i.e., the Marlin cyanide facilities) have been decommissioned and are no longer operating. Marlin does not need a detailed emergency response plans for potential cyanide releases because there is no cyanide at Marlin.

**Standard of Practice 7.2**

*Involve site personnel and stakeholders in the planning process.*

The operation is:             not subject to  
    subject to  
Standard of Practice 7.2

*Describe the basis for the Finding/Deficiencies Identified:*

Goldcorp – Marlin Mine  
Name of Operation

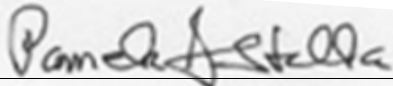
  
Signature of Lead Auditor

December 15, 2017  
Date

**Pamela Stella Environmental Mining Services LLC**

This ICMC Standard of Practice is not applicable to the Marlin Mine because the operation no longer uses cyanide at the site for the recovery of gold and cyanide is no longer stored or mixed on site. The process facilities previously used for the unloading, storage and mixing of cyanide and for the recovery of gold (i.e., the Marlin cyanide facilities) have been decommissioned and are no longer operating.

**Standard of Practice 7.3**

***Designate appropriate personnel and commit necessary equipment and resources for emergency response.***

The operation is:      not subject to  
                               subject to  
                              Standard of Practice 7.3

*Describe the basis for the Finding/Deficiencies Identified:*

This ICMC Standard of Practice is not applicable to the Marlin Mine because the operation no longer uses cyanide at the site for the recovery of gold and cyanide is no longer stored or mixed on site. The process facilities previously used for the unloading, storage and mixing of cyanide and for the recovery of gold (i.e., the Marlin cyanide facilities) have been decommissioned and are no longer operating.

**Standard of Practice 7.4**

***Develop procedures for internal and external emergency notification and reporting.***

The operation is:      not subject to  
                               subject to  
                              Standard of Practice 7.4

*Describe the basis for the Finding/Deficiencies Identified:*

---

Goldcorp – Marlin Mine  
Name of Operation

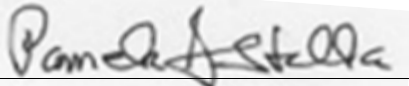
  
Signature of Lead Auditor  
**Pamela Stella Environmental Mining Services LLC**

December 15, 2017  
Date

This ICMC Standard of Practice is not applicable to the Marlin Mine because the operation no longer uses cyanide at the site for the recovery of gold and cyanide is no longer stored or mixed on site. The process facilities previously used for the unloading, storage and mixing of cyanide and for the recovery of gold (i.e., the Marlin cyanide facilities) have been decommissioned and are no longer operating.

**Standard of Practice 7.5**

*Incorporate into response plans monitoring elements and remediation measures that account for the additional hazards of using cyanide treatment chemicals.*

The operation is:       not subject to  
                                  subject to  
                                 Standard of Practice 7.5

*Describe the basis for the Finding/Deficiencies Identified:*

This ICMC Standard of Practice is not applicable to the Marlin Mine because the operation no longer uses cyanide at the site for the recovery of gold and cyanide is no longer stored or mixed on site. The process facilities previously used for the unloading, storage and mixing of cyanide and for the recovery of gold (i.e., the Marlin cyanide facilities) have been decommissioned and are no longer operating.

**Standard of Practice 7.6**

*Periodically evaluate response procedures and capabilities and revise them as needed.*

The operation is:       not subject to  
                                  subject to  
                                 Standard of Practice 7.6

*Describe the basis for the Finding/Deficiencies Identified:*

Goldcorp – Marlin Mine  
Name of Operation

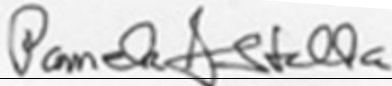
  
Signature of Lead Auditor

December 15, 2017  
Date

**Pamela Stella Environmental Mining Services LLC**

---

This ICMC Standard of Practice is not applicable to the Marlin Mine because the operation no longer uses cyanide at the site for the recovery of gold and cyanide is no longer stored or mixed on site. The process facilities previously used for the unloading, storage and mixing of cyanide and for the recovery of gold (i.e., the Marlin cyanide facilities) have been decommissioned and are no longer.

## **8.0 TRAINING**

***Train workers and emergency response personnel to manage cyanide in a safe and environmentally protective manner.***

### **Standard of Practice 8.1**

***Train workers to understand the hazards associated with cyanide use.***

The operation is:      not subject to  
                                   subject to  
                                  Standard of Practice 8.1

*Describe the basis for the Finding/Deficiencies Identified:*

This ICMC Standard of Practice is not applicable to the Marlin Mine because the operation no longer uses cyanide at the site for the recovery of gold and cyanide is no longer stored or mixed on site. The process facilities previously used for the unloading, storage and mixing of cyanide and for the recovery of gold (i.e., the Marlin cyanide facilities) have been decommissioned and are no longer.

### **Standard of Practice 8.2**

***Train appropriate personnel to operate the facility according to systems and procedures that protect human health, the community and the environment.***

The operation is:      not subject to  
                                   subject to  
                                  Standard of Practice 8.2

---

Goldcorp – Marlin Mine

Name of Operation



Signature of Lead Auditor

December 15, 2017

Date

**Pamela Stella Environmental Mining Services LLC**

---

*Describe the basis for the Finding/Deficiencies Identified:*

This ICMC Standard of Practice is not applicable to the Marlin Mine because the operation no longer uses cyanide at the site for the recovery of gold and cyanide is no longer stored or mixed on site. The process facilities previously used for the unloading, storage and mixing of cyanide and for the recovery of gold (i.e., the Marlin cyanide facilities) have been decommissioned and are no longer.

**Standard of Practice 8.3**

***Train appropriate workers and personnel to respond to worker exposures and environmental releases of cyanide.***

The operation is:       not subject to  
                                   subject to  
                                  Standard of Practice 8.3

*Describe the basis for the Finding/Deficiencies Identified:*

This ICMC Standard of Practice is not applicable to the Marlin Mine because the operation no longer uses cyanide at the site for the recovery of gold and cyanide is no longer stored or mixed on site. The process facilities previously used for the unloading, storage and mixing of cyanide and for the recovery of gold (i.e., the Marlin cyanide facilities) have been decommissioned and are no longer.

**9.0 DIALOGUE**

***Engage in public consultation and disclosure.***

**Standard of Practice 9.1**

***Provide stakeholders the opportunity to communicate issues of concern.***

The operation is:       not subject to

---

Goldcorp – Marlin Mine  
Name of Operation

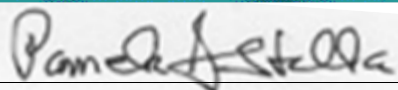
  
Signature of Lead Auditor

December 15, 2017  
Date

**Pamela Stella Environmental Mining Services LLC**

---

subject to  
Standard of Practice 9.1

*Describe the basis for the Finding/Deficiencies Identified:*

This ICMC Standard of Practice is not applicable to the Marlin Mine because the operation no longer uses cyanide at the site for the recovery of gold and cyanide is no longer stored or mixed on site. The process facilities previously used for the unloading, storage and mixing of cyanide and for the recovery of gold (i.e., the Marlin cyanide facilities) have been decommissioned and are no longer.

Goldcorp's Sustainability Excellence Management System (SEMS) Framework and Standards (June 2017) includes Standard 10, Closure Planning. The SEMS has been formally adopted as the Corporate standard and implementation guideline for environmental stewardship. This Standard requires Goldcorp mining operations to comply with all applicable local laws and regulations, international guidelines and the ICMC, and results in returning mine sites to long-term safe and stable conditions. The Standard also requires that stakeholders must be informed when there is a significant material change at the site. The Standard includes requirements for:

- Terms of reference for reclamation and closure activities will be explicitly documented in the life-of-mine closure plan.
- Applicable regulatory standards, closure performance objectives, permitting and approval requirements, and procedures for release of financial assurance upon completion of the work
- Clear definition of the pre and post-mining land use, evaluation of alternative sustainable uses, and a discussion of land ownership/transfer mechanisms
- A clear definition of key technical and social assumptions, with a list of data requirements pre and post closure

---

Goldcorp – Marlin Mine

Name of Operation

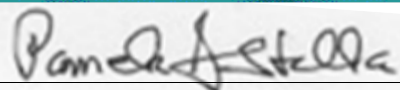

Signature of Lead Auditor

December 15, 2017

Date

**Pamela Stella Environmental Mining Services LLC**

- A schedule of closure activities to address impact assumptions and gaps
- A closure-focused engagement plan
- Community development initiatives during the closure phase, including how operations phase initiatives will be concluded or handed off
- Consideration of local and regional partnerships and agreements.

Marlin has been communicating to the communities regarding closure of the Marlin Mine since 2013. The communication started at the closest communities, New Esparanza (1 kilometer away) and San Jose Ixcaniche (1.5 kilometers). The leaders of these two communities visit the on-site community relations' office through their open door policy.

Marlin distributes monthly community newsletters through their three community offices. Since July 2016 Marlin has held meetings at communities located farther away from the site. These communities included Sipacapa (20 kilometers), San Miguel Ixtahuacan (25 kilometers) and Marlin. The Mayor and representatives attended these meetings from the health department, civil protection, Ministry of Mines and Ministry of Environment and Natural Resources.

Marlin will donate part of the lands to the communities surrounding the Marlin mine and the rest will be donated to the Sierra Madre Foundation, a foundation established by Marlin. Marlin's goal is to promote a sustainable Foundation for the long-term.

**Standard of Practice 9.2**

*Initiate dialogue describing cyanide management procedures and responsively address identified concerns.*

The operation is:  not subject to  
 subject to  
 Standard of Practice 9.2

Goldcorp – Marlin Mine  
 Name of Operation

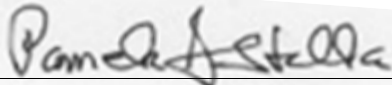
  
 Signature of Lead Auditor

December 15, 2017  
 Date

**Pamela Stella Environmental Mining Services LLC**



---

*Describe the basis for the Finding/Deficiencies Identified:*

This ICMC Standard of Practice is not applicable to the Marlin Mine because the operation no longer uses cyanide at the site for the recovery of gold and cyanide is no longer stored or mixed on site. The process facilities previously used for the unloading, storage and mixing of cyanide and for the recovery of gold (i.e., the Marlin cyanide facilities) have been decommissioned and are no longer operating.

**Standard of Practice 9.3**

***Make appropriate operational and environmental information regarding cyanide available to stakeholders.***

The operation is:      not subject to  
                                   subject to  
                                  Standard of Practice 9.3

*Describe the basis for the Finding/Deficiencies Identified:*

This ICMC Standard of Practice is not applicable to the Marlin Mine as the operation no longer uses cyanide at the site for the recovery of gold and cyanide is no longer stored or mixed on site. The process facilities previously used for the unloading, storage and mixing of cyanide and for the recovery of gold (i.e., the Marlin cyanide facilities) have been decommissioned and are no longer operating.

---

Goldcorp – Marlin Mine  
Name of Operation

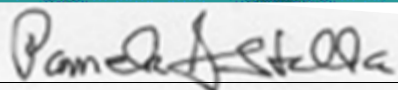
  
Signature of Lead Auditor

December 15, 2017  
Date

**Pamela Stella Environmental Mining Services LLC**

---

**REFERENCES**

ICMC Recertification Detailed Audit Report Marlin Mine Guatemala by Golder Associates Inc. April 2016.

Marlin Mine Closure Plan November 2014

Runoff Management Design Marlin Mine March 2017

Plant Closure Plan (Cleaning) September 2016 Prepared for the Environmental Directorate of the Ministry of Environment and Natural Resource Government of Guatemala

Cleaning of Process Plant Tanks July 2015

Cleaning of Tanks, Pipelines and Accessories that Contain Sodium Cyanide Solution Prior to Maintenance (Decontamination) March 2009

International Cyanide Management Code (ICMC). 2016. [www.cyanidecode.org](http://www.cyanidecode.org)

---

Goldcorp – Marlin Mine

Name of Operation

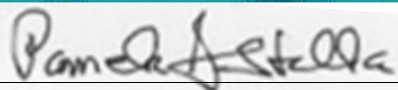

Signature of Lead Auditor

December 15, 2017

Date

**Pamela Stella Environmental Mining Services LLC**